

MSF-43AN

Standard features include baskets, integrated basket dividers, external thermometer and lock.

M B MASTER-BILT[®]

COLDIN-3™ SERIES

MSF-AN SERIES

Flat Lid Display Freezers

MODELS

- MSF-31AN
- MSF-43AN
- MSF-52AN
- MSF-71AN

FEATURES

CONSTRUCTION

- Standard interior LED lighting with separate on/off switch
- Tempered glass sliding lids
- White zinc-coated baked-on enamel steel exterior
- Painted white powder-coated steel interior
- Flat top three-compartment baskets
- Removable rubber bumper guards on grille side

- Heavy-duty casters, two locking
- Bottom drain with plug
- Lid lock and keys
- The unobtrusive frame around the glass lids ensures a highly visible display
- External analog thermometer display
- Control panel with adjustable temperature range of +10 to -18°F
- Low energy consumption

REFRIGERATION

- Refrigerant: R290
- Temperature range: -18° to 10°F (-27° to -12°C)

WARRANTY

- Standard limited one year parts and labor
- Additional four year coverage on compressor part

STANDARD BASKETS

MSF-AN merchandisers are supplied with equally-sized baskets and two fixed dividers per basket.

| MODEL | NO. OF BASKETS |
|----------|----------------|
| MSF-31AN | 2 |
| MSF-43AN | 3 |
| MSF-52AN | 4 |
| MSF-71AN | 5 |

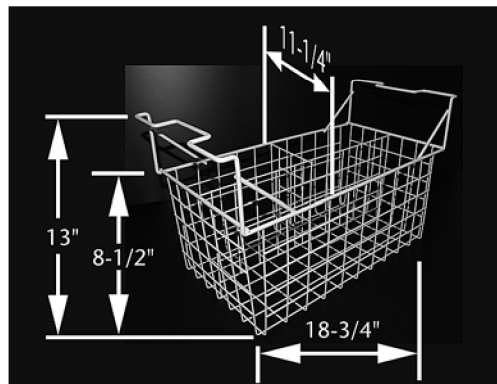

One vertical and one horizontal fixed divider in each basket.



COLDIN-3™ MSF-AN SERIES FLAT LID DISPLAY FREEZERS

TECHNICAL SPECIFICATIONS

| MODEL | DIMENSIONS (in.) | | | DIMENSIONS (mm) | | | VOLTS | AMPS | UNIT H.P. | GROSS CU. FT. | NET CU. FT. | SHIP CU. FT. | SHIP WT. LB/KG |
|----------|------------------|----|----|-----------------|-----|-----|-------|------|-----------|---------------|-------------|--------------|----------------|
| | L | D | H | L | D | H | | | | | | | |
| MSF-31AN | 31 | 27 | 33 | 787 | 686 | 851 | 115 | 1.1 | 1/3 | 7.4 | 5.8 | 20.7 | 181/82 |
| MSF-43AN | 43 | 27 | 33 | 1092 | 686 | 851 | 115 | 1.1 | 1/3 | 11.1 | 8.8 | 27.8 | 192/87 |
| MSF-52AN | 52 | 27 | 33 | 1321 | 686 | 851 | 115 | 1.3 | 1/3 | 13.8 | 11.0 | 33.1 | 213/97 |
| MSF-71AN | 71 | 27 | 33 | 1803 | 686 | 851 | 115 | 3.9 | 2/3 | 20.0 | 15.9 | 44.3 | 269/122 |

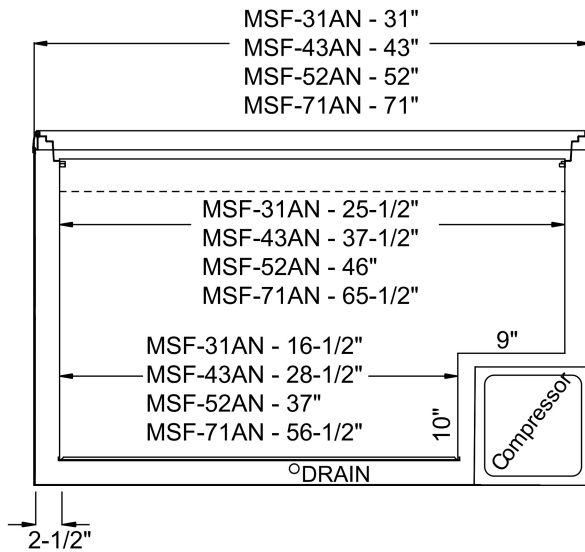

ELEVATION VIEW

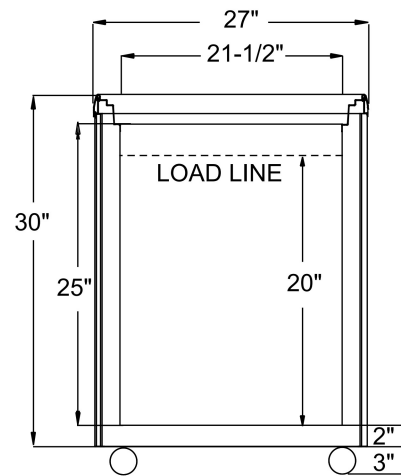

SIDE VIEW

LISTINGS



HOOKUP

Via plug in, 6 1/2 ft. long, flexible 3 wire 14AWG/3 cord with molded plug.



BID SPECIFICATIONS

Item no. MSF-_____AN
Provide _____ () Standard Display Freezer(s) Master-Bilt® model MSF-_____AN.

Freezer to be constructed of a white zinc-coated baked-on enamel on steel exterior with painted white powder-coated steel interior. Freezer to be furnished with

standard LED interior lighting. Also standard with baskets, integrated basket dividers, external thermometer and lock. Additionally, it will be provided with heavy-duty casters and a defrost water drain. Lids will contain tempered safety glass.

Refrigeration system will use R290 refrigerant in all models. The temperature range will be -18° to 10°F (-27° to -12°C).

Freezer to have standard limited one year parts and labor with additional four year coverage on compressor part.

Freezer to be ETL listed in the U.S. and Canada and ETL Sanitation listed.

NOTE: Cabinet designed for optimum performance in air-conditioned area at 75°F ambient and 55% relative humidity. All specifications subject to change without notice.



908 Highway 15 North • New Albany, MS 38652
PHONE: 800-647-1284 or 662-534-9061 • FAX: 800-232-3966 or 662-534-6049 • www.master-bilt.com